

参考図

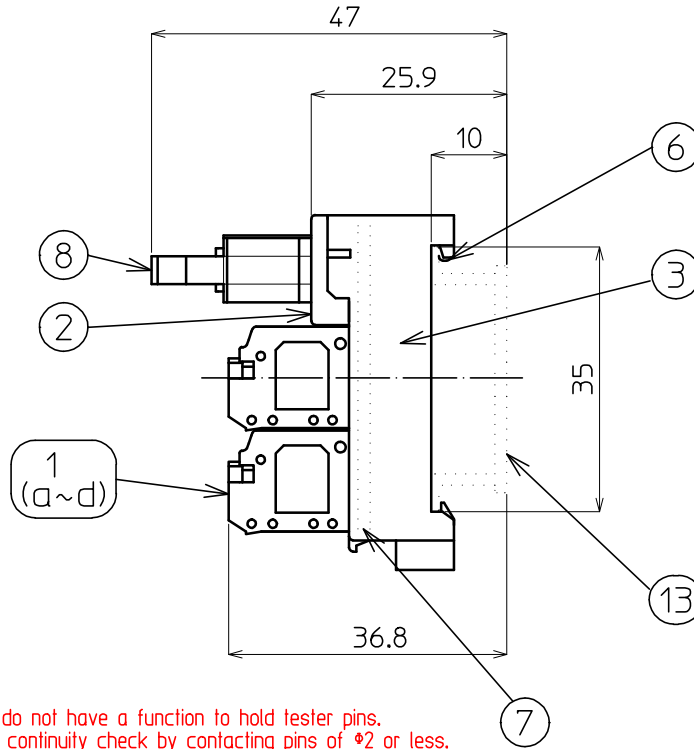

Check hole (MAX ϕ 2)
 Note : The check holes do not have a function to hold tester pins.
 Please use for continuity check by contacting pins of ϕ 2 or less.
 Please note that forcibly pushing and holding the tester pins may cause malfunction.

Insertion hole
 Note : Wire with insulation diameter of ϕ 3.2 or more cannot be used.

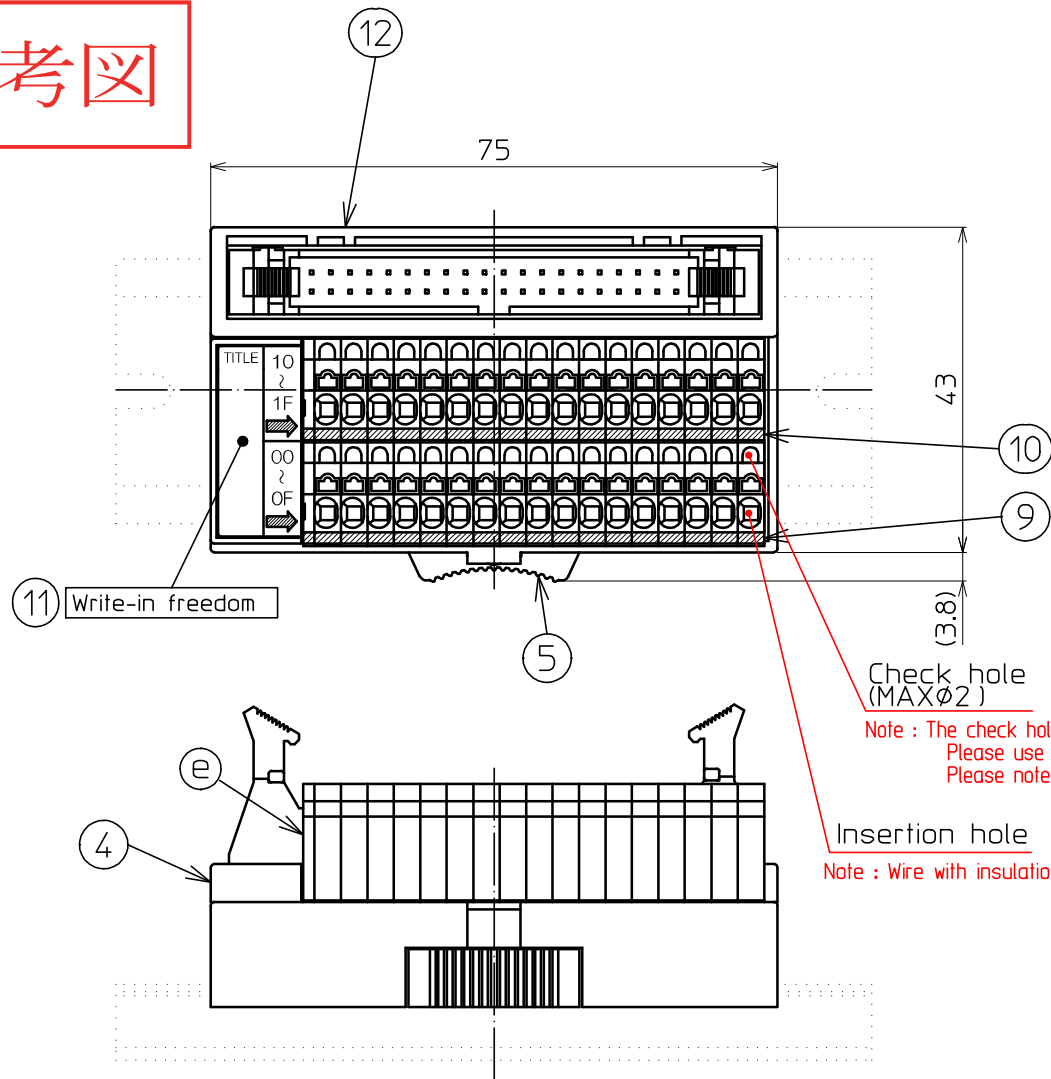
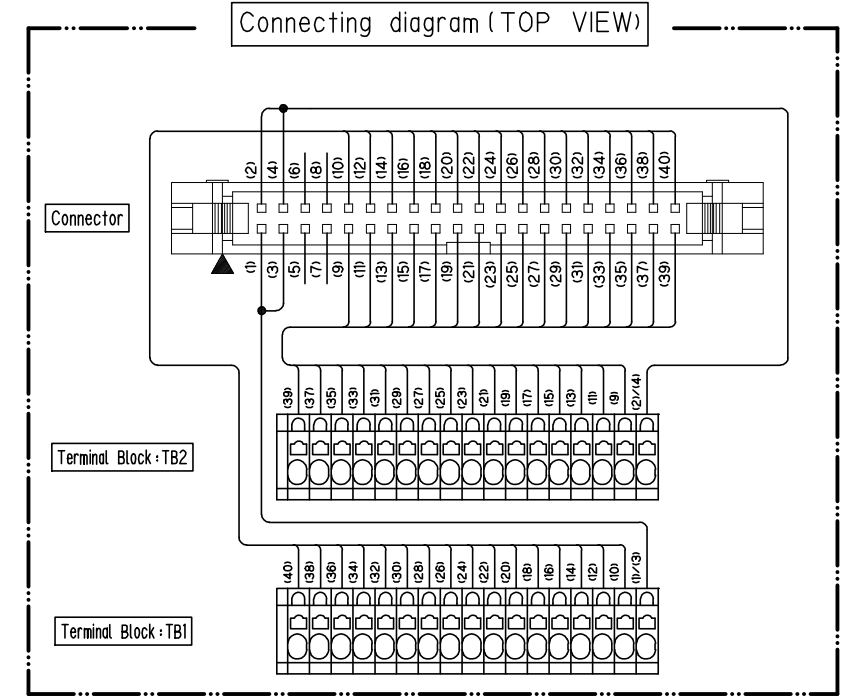

No.	The contents of printing
⑩	10 11 12 13 14 15 16 17 18 19 1A 1B 1C 1D 1E 1F +V
⑨	00 01 02 03 04 05 06 07 08 09 0A 0B 0C 0D 0E 0F 0V

Specification

No.	Description	Material	Size	Surface Treatment	Remarks	Quantity
1	Terminal Block 17P					2
a	Base	66Nylon(Gray)		Sn	UL94V-0	17set
b	Conductive Plate	Copper alloy				
c	Button	66Nylon(Orange)			UL94V-0	
d	Connecting Spring	SUS				
e	Side Plate	66Nylon(Gray)			UL94V-0	
2	Upper case	PBT (Ivory)			UL94V-0	1
3	Lower case	PBT (Ivory)			UL94V-0	1
4	Seal base	PBT (Ivory)			UL94V-0	1
5	Lock button	POM (yellow)				1
6	Spring	SUS				1
7	Substrate	Glass epoxy	t=1.6			1
8	Connector				HIROSE : HIF3BA-40PA-2.54DSA(63)	1
9	Name seal TB1					1
10	Name seal TB2					1
11	Title seal					1
12	Seal of form					1
13	Rail DIN35mm				* Optional	1

Rateds

Rating voltage	50V
Rating current	Sig:0.5A COM:2A
Insulation resistance	100M Ω or above (With DC500V)
Withstand voltage	AC500V / 1minute
Connectable wire	Pressure terminal 0.14mm ² ~ 0.75mm ² / AWG26~AWG18 Conformity DIN46228-4 8~12mm
	Single ϕ 0.3~ ϕ 1.3 9~10mm
	Twist 0.08mm ² ~ 1.5mm ² / MAX AWG28~AWG16 9~10mm
Operating ambient temperature	-15 $^{\circ}$ C~+60 $^{\circ}$ C(No freezing or condensation)
Relative humidity	45~85%

*Solid/Stranded wires with insulation of ϕ 3.2 or more cannot be used.

Weight 78g

How to move the unit attached to the DIN (35-mm width) rail

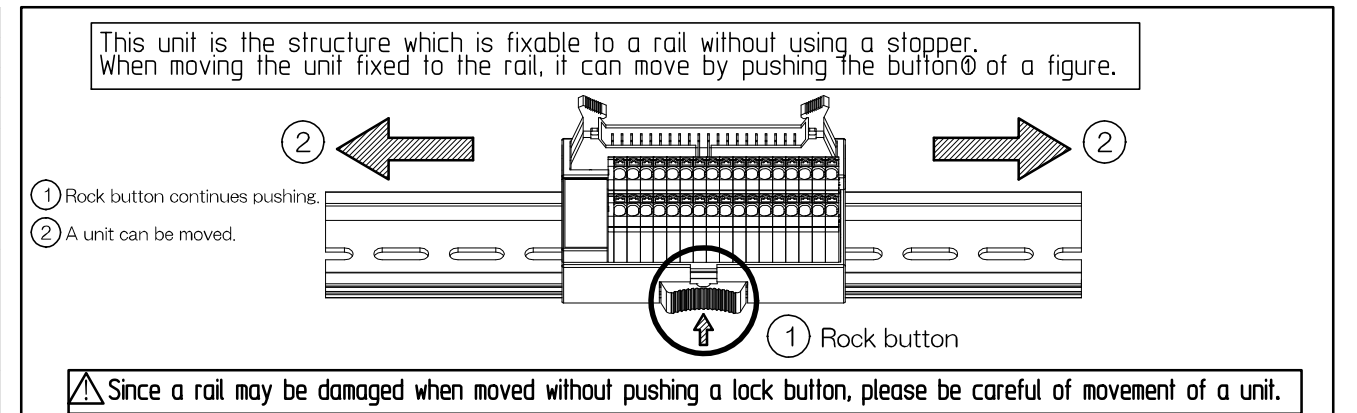

承認 APPROVED 菅沼 2013. 2/12	検図 CHECKED 小松 2013. 2/12	製図 DRAWING 宮澤	設計 DESIGNED	名称 TITLE PCX-1H40-TB34-M2-Y
製品コード CODE No.		単位 UNIT mm	尺度 SCALE 1 / 1	番 DRAWING No. TA13088-01
公差 TOLERANCE		REV. SHEET 1 / 1		

改番 REV.	訂正記事 DESCRIPTION OF REVISION	年月日 DATE	担当 BY