

参考図

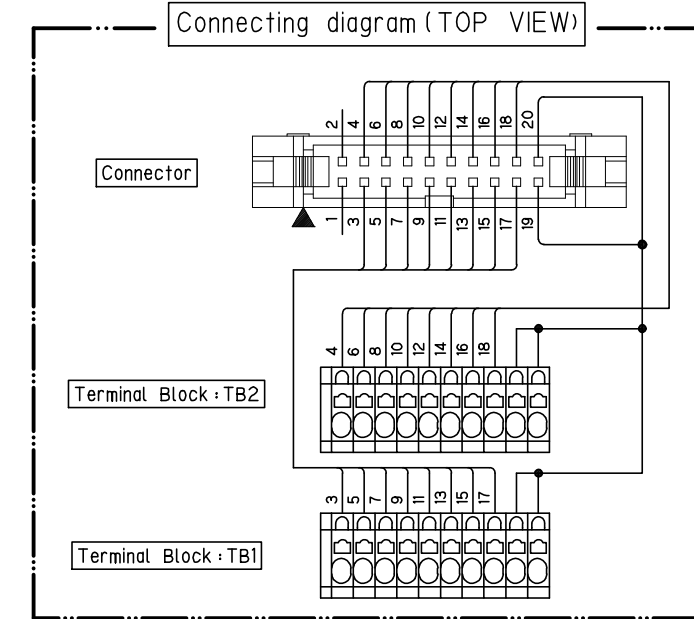
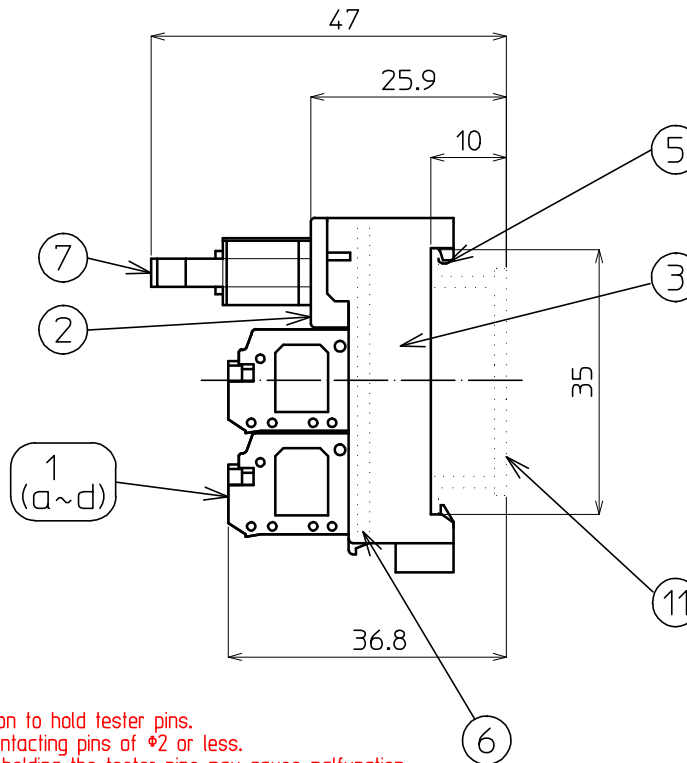
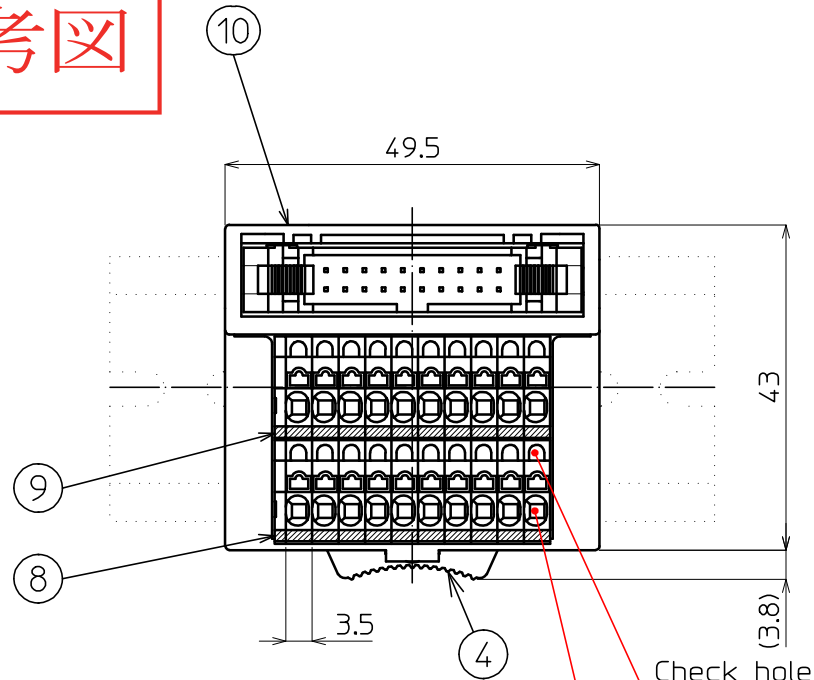

Check hole (MAX ϕ 2)

Note : The check holes do not have a function to hold tester pins.
Please use for continuity check by contacting pins of ϕ 2 or less.
Please note that forcibly pushing and holding the tester pins may cause malfunction.

Insertion hole

Note : Wire with insulation diameter of ϕ 3.2 or more cannot be used.

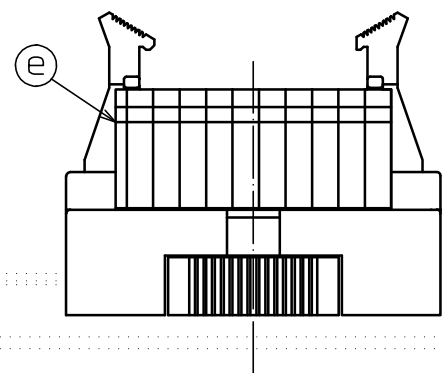

No.	The contents of printing
⑨	008 009 010 011 012 013 014 015 COM
⑧	000 001 002 003 004 005 006 007 COM

Specification

No.	Description	Material	Size	Surface Treatment	Remarks	Quantity
1	Terminal Block 10P					2
a	Base	66Nylon(Gray)		Sn	UL94V-0	10set
b	Conductive Plate	Copper alloy				
c	Button	66Nylon(Orange)			UL94V-0	
d	Connecting Spring	SUS				
e	Side Plate	66Nylon(Gray)			UL94V-0	
2	Upper case	PBT (Ivory)			UL94V-0	1
3	Lower case	PBT (Ivory)			UL94V-0	1
4	Lock button	POM (yellow)				1
5	Spring	SUS				1
6	Substrate	Glass epoxy	t=1.6			1
7	Connector				HIROSE : HIF3BA-20PA-254DSA(63)	1
8	Name seal TB1					1
9	Name seal TB2					1
10	Seal of form					1
11	Rail DIN35mm				* Optional	1

Rateds

Rating voltage	50V
Rating current	Sig:0.5A COM:2A
Insulation resistance	100M Ω or above (With DC500V)
Withstand voltage	AC500V / 1minute
Connectable wire	Pressure terminal 0.14mm ² ~ 0.75mm ² / AWG26~AWG18 Conformity DIN46228-4 8~12mm
	Single ϕ 0.3~ ϕ 1.3 9~10mm
	Twist 0.08mm ² ~ 1.5mm ² / MAX AWG28~AWG16 9~10mm
Operating ambient temperature	-15 $^{\circ}$ C~+60 $^{\circ}$ C(No freezing or condensation)
Relative humidity	45~85%

*Solid/Stranded wires with insulation of ϕ 3.2 or more cannot be used.

Weight 約50g

How to move the unit attached to the DIN (35-mm width) rail

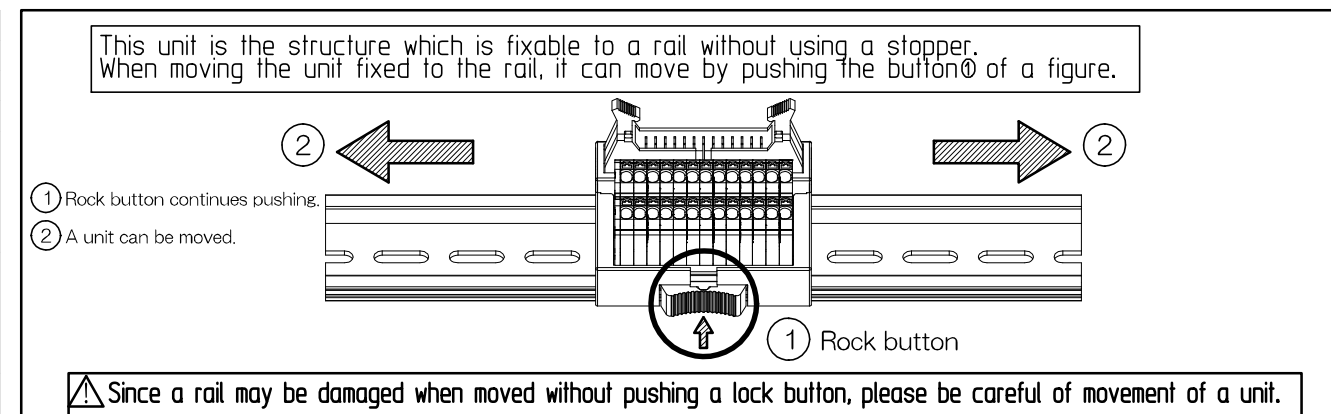

承認 APPROVED	検閲 CHECKED	製図 DRAWING	設計 DESIGNED	名称 TITLE
菅沼 2016. 2/15	小松 2016. 2/15	宮澤		PCX-1H20-TB20-K2
製品コード CODE No.		単位 UNIT	尺度 SCALE	Specifications
		mm	1 / 1	
		公差 TOLERANCE		図番 DRAWING No.
				TA16105-01
				REV. SHEET
				1 / 1

改番 REV.	訂正記事 DESCRIPTION OF REVISION	年月日 DATE	担当 BY