

# Accessories

Terminal block for optional installation

## CNT15-10 600V / 15A / 2mm<sup>2</sup> [Screw size M3.5] / 10poles



Weight: 77g  
Sales lot: 1pc

### Dimension

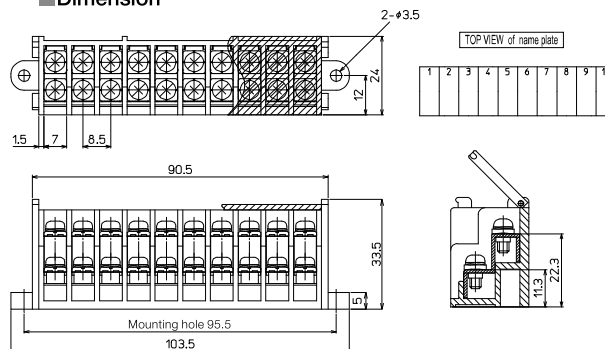

### Applicable crimp terminal

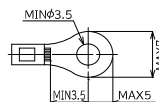

### Applicable Short bar

BB8.5-2, 4, 8, 10 (see P.20)

### Specifications

Rated voltage	AC,DC 600V
Rated current	15A
Insulation resistance	100MΩ or more (DC500V)
Withstand voltage	AC 2500V / min
Applicable wire	2.0mm <sup>2</sup> / MAX
Tightening torque	1.4N · m
Ambient temperature	-25°C ~ +100°C (No freezing and condensations)
Relative humidity	45%~85%

### Materials

Terminal block main body	PBT (UL94V-0)
Conductive plate	Brass (Ni plating)
Terminal Screw	SWCH (Zn+trivalent chromate-plating) M3.5x8L
Cover	PC (UL94V-2)
Name plate	Paper

## Installation plate set

### BOXTM20-05 \*For BOXTM-2000 and BOXTM-2003



Weight: 74g  
Sales lot: 1set

### Dimension

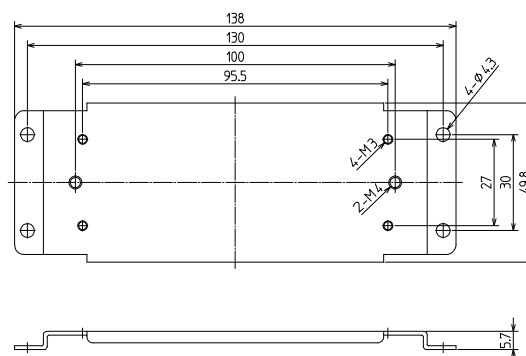

### Set contents

Description	Material	Qty.
Installation plate for terminal (t=12)	SPCC (Zinc plating)	1
Self-tapping screw (Nonimal Diameter 4x10L)	SWCH (Zinc plating)	4
Screw (M3x10L)	SWCH (Zinc plating)	4